

Statoil Tide Gage 2009 (TG09)

** Primary Investigators: Mark Zumberge & Glenn Sasagawa
** Electronics: Mike Kirk
** Firmware: Mike Kirk & Michael Davis
** Mechanical (Chassis & Deployment Frame): John Lyons & Dave Aglietti
** Funding by StatOil

TG09 builds on the previous TG07 using the same electronics & pressure case with new code, pressure lid and the Model 31K 1000 psia Paroscientific pressure transducer with RS232 intelligence card now in the same main p-case eliminating one external u/w connector. The new p-lid has only 2 u/w SubConn connectors and the Paros pressure port.

Major Changes:

LinkQuest Acoustic modem replaces the Benthos modem
New Paros intelligence card allows for simultaneous pressure & temperature measurements
LinkQuest Acoustic Modem & Comm Test are the only bulkhead connectors.

Max. Pressure Ratings:

1. 670m with the installed 1000 psia pressure transducer
2. 680m pressure housing tested in pressure chamber
3. 1350m max pressure housing (3400m crush depth)
(very conservative but need to pressure test housing before going beyond this)

The internal Paros mount is for the larger Paros 31K 1000 psia pressure transducer.
There is a white plastic sleeve with a height adjusting screw for the 410K model.

LinkQuest to ROV Mounting & Comms

There are 2 externally identical LinkQuest modems. One is labeled Surface and ROV. This is the one to mount on the ROV. The other is labeled Bottom and goes with the TG09. The internal differences are just programming with the ROV consuming much more power. The TG09 (Bottom) LinkQuest is optimized for low power.

ROV LinkQuest should be mounted high with the transducer having a 360 degree view and forward / away from the thrusters and any other noise sources (i.e., other transducers).

See the separate TideGage2009_to_ROV.doc for details on power and comms.

Power: +24 VDC +10% max. Comms: same as ROVDOG (9600, 8, N, 1)

There is an adapter cable to test/check with the same ROVDOG test boxes.

To test comms to ROV LinkQuest

(see LinkQuest manual for details and troubleshooting)

From a Windows XP command window: Start-Run type in cmd & hit Enter

Change to the LinkQuest directory with the LinkQuest *.exe commands

Send the LinkQuest rs232 command

rs232 <com port> <filename>

So for com port 1 (laptop serial) & rs232_051909.dat (save these files with a date tag)

rs232 1 rs232_051909.dat

If it passes, there will be a series of binary numbers followed by

Output: RS232 Test Passed. No error.

(You can also do this from a terminal window sending an ASCII command string.

These have an arbitrary *.lqc extension and will be incorporated into a LabView vi)

Once you have power and comms, that is the limit of LinkQuest testing on the surface.

TG09 Deployment Procedure

TG09 has battery installed, initial checks completed and pressure case is sealed.
(otherwise go to Startup Procedure section)

Statoil Tide Gage 2009 (TG09)

Connect TG09 Comm port cable to TG09 and to laptop (9600, 8, 1, N) for last check prior to deployment.

TG09 LinkQuest modem is always listening acoustically. This is independent of whatever the datalogger is doing. The LinkQuest modem has an adjustable wakeup period presently set for 20 seconds. It can be adjusted from 120 seconds to always on in increments of 5 seconds. Always on = more power. 120 seconds = very slow to wake up.

This always happens at the top of each hour:

Comm port output:

1. Top of each hour: Timestamp, TiltX, TiltY, TiltT,
2. 64 seconds later: Pc
3. 58.5 seconds 59 times : Pc
4. Cycle repeats top of next hour

Connecting acoustically to TG09, either test tank or during deploy

Connect using LinkQuest bypass cable to PC terminal program (HyperTerm, Serial 9600, 8, 1,N)

HyperTerm: Click File-Properties-Settings-ASCII Setup

Check box Echo typed characters locally

Clear all other boxes especially Wrap lines that exceed terminal width

(Careful with the terminal program used. Some will add CR/LF to every screen width line. HyperTerm does not if correctly set.)

Testing prior to deployment:

Air testing just doesn't work with the new LinkQuest modems.

There is a LinkQuest Bypass serial test cable to test everything except the actual acoustic link.

(Limited acoustic link testing can be done in at least a 50 gal water tank with the 2 modems centered & touching transducers.)

Also connect TG09 Comm port cable to TG09 and log debug responses (this is another laptop serial port running HyperTerm, Serial 9600, 8, 1, N) . This just monitors TG09. Do send any commands using this.



Off loading the data with the LinkQuest modem (or direct serial cable)

The surface LinkQuest modem will be mounted on the ROV.

All RS232 serial comms: 9600, 8, 1, N

Before leaving the dock or anytime TG09 is not deployed, it would a good idea to go through the LinkQuest link up and data offload using the LinkQuest Bypass serial cable. This is cable #1 described below.

There are 3 35m (100'+) black cables on orange spools

Orange Spool Cable #1 This 35m (100'+) black cable has a SubConn MCIL8M (8 pin male) connector on one end and a DB9 on the other. Disconnect the LinkQuest cable at the TG09 p-lid and connect this one. This will bypass both LinkQuest modems to allow testing and offloading data while TG09 is on the surface either before deployment or between stations.

Orange Spool Cable #2 This 35m (100'+) black cable has a SubConn MCIL5M (5 pin male) connector on one end and a DB9 on the other. Remove the dummy plug on the TG09 p-lid and connect this one. This allows monitoring of the TG09 program including local responses to data offload commands. See below for description

Orange Spool Cable #3 This 35m (100'+) black cable on an has a SubConn MCIL8F (8 pin female) connector on one end and a ROVDOG style CPC connector on the other. Disconnect the LinkQuest cable at the ROV LinkQuest and connect this one. The CPC connector can connect to any ROVDOG deck box for testing. There is also a shorter black cable with the mating CPC connector on one end and a DB9 and power connector on the other. There are 2 +15 VDC power supplies to provide power to the ROV/Surface LinkQuest modem. This was used for the testing off the Scripps pier and could also be used for shipboard over the side acoustic linking to TG09 if the ROV does not pan out for some reason.

Connecting to TG09 and LinkQuest modems is a 2 step process.

Step 1 Connect to the LinkQuest Bottom Modem

(see LinkQuest manual for more details)

This is best done from a Windows XP command window: Start-Run type in cmd & hit Enter

Statoil Tide Gage 2009 (TG09)

Change to the LinkQuest directory with the LinkQuest *.exe commands

- A. Send the LinkQuest mdm_sync command
(You can also do this from a terminal window sending an ASCII command string.
These have an arbitrary *.lqc extension and will be incorporated into a LabView vi)
- B. Since the bottom modem is in the low power mode, it will take a few minutes to link up
- C. If everything looks good after linking, you will get a Range & the Quality of the communications channel.
- D. If all is good, proceed to Step 2
- D. Otherwise, try a couple more times. Also, see LinkQuest manual for troubleshooting

Open a log file & save everything.

Step 2 Connect to TG09 program (Persistor CF2)

(both modems are just a conduit, TG09 CF2 program is in charge)

- A. Send several any character (just hit space bar several times)
- B. Wait for WAKE1, WAKE2, WAKE3 to be returned (may take a few minutes)
- C. now send ACT1 (maybe twice) to activate the TG09
- D. once activated, the response will be RAK
RAK is from the TG09

Refer to TG09 Commands for communication options.

Before uploading files, send the NID, CTD & BAT commands as a minimum.

Log responses in the ROVDOG log book. We want to track the battery voltages during the cruise.

Other LinkQuest commands once connected (see LinkQuest manual)

Good idea to do the LinkQuest noise test.

Get range from the mdm_sync command

*** Read the manual! Some commands are very time intensive so be careful before using.

Note that both modems default to low power.

If high power is needed, set the surface/ROV modem to high power.

mdm_sync will set the bottom modem the same

Verify both

mdm_sync also resets both modems so mdm_rst is redundant although is much quicker for just one modem

Statoil Tide Gage 2009 (TG09)
TG09 Commands

TG09- to get online Step 1 send mdm_sync to LinkQuest modem and Step 2 TG09 ID = 1: **ACT1**
(There is an option to have different IDs for both the data logger & modem)

<Caps Lock> on please.

All replies are ASCII and will also echo diagnostic info to the comm. Port .

Single Queries (any order after ACT)

Topside Command		Underwater Reply	Acknowledges or Replies
ACT1	Activate TG09 #1	RAK<cr><lf>	TG09 is now active
NID	Request TG09 ID #	RNID1<cr><lf>	Replies w/ TG09 ID
CTD	Request time/date	RTIM<ddd>.<yy><sp> <hh>:<mm>:<ss><cr><lf>	JulianDay.Year Hr:Min:Sec
BAT	Request battery voltage	RBVbb.bb<cr><lf>	Battery Voltage
GCR	Request time/date, tilt data; (no P, takes 58.5 seconds!!)	RCSS<cr><lf> followed by file current.erd	Date, time, TiltX, TiltY, TiltT, are logged to the ASCII file current.erd which is uploaded (no P yet)
INFO	Request CF card size & free space	Free=0256475136 <cr><lf> Total=0256614400<cr><lf>	CF card size & free space
VER		none	Version info, comm port only
EXITI	Exits Interactive Mode	RIGE<cr><lf>	Exit & shut down until next hour ***

May 2009: Do not use the GCR or INFO commands. Both are buggy (last minute discovery)

Data Offload Sequential (top to bottom)

(Initially, just upload 2-3 days max at a time until the actual data rate can be determined)

Topside Command		Underwater Reply	Acknowledges or Replies
DXR	Data Transfer Request	RXR <cr><lf>	DXR cmd
SD=<ddd><yy>	Start Date (day of year)	RSD<ddd><yy><cr><lf>	SD cmd
ED=<ddd><yy>	End Date	RED<ddd><yy><cr><lf>	ED cmd
None but after above	Send number files available	NFF<nnn><cr><lf>	
GO	Start Data Transfer	Data upload starts	none
none	Data upload continues	DOF<cr><lf>	Data Transfer Complete
<i>To abort:</i>			
SXR	Aborts sequence before GO	RSXR<cr><lf>	<u>Confirm responses!</u> Abort if not correct & start over. NFF should have some # of files. If 0, abort & try again.

*** There is a 5 minute modem low power timeout.

*** After uploading data, there will be an ASCII 'DOF' sent at the end. Look for this to confirm upload is complete.

*** **Be careful with the EXITI Exit Command. When used, the TG09 will shut down until the next hour.**

*** Prior to deployment

check CF card with INFO command which returns card size and free space. INFO also works acoustically.

CF card can be read by a laptop USB multi-card type reader

Daily files are stored in a DATA subdirectory

Filenames are <ddd>.<yy> where ddd is the julian day & yy is the 2 digit year

Just copy the files & nothing else.

Especially, do not format & write to the CF card using the laptop USB reader.

Use the Persistor PicoDOS for any CF card housekeeping.

With a 128MB CF card, there is room for over 20 years of data, so no worries about space.

Statoil Tide Gage 2009 (TG09) Data File Format

Files are stored on the TG09 CF memory card in a subdirectory named DATA.
Files are daily named ddd.yy where ddd is the julian day & yy is the 2 digit year so the day file for 5/29/2007 is 149.07
If needed, you can just read the CF card using an USB memory card reader. Just do not write, save, format or anything using WinDoz. Use only PicoDOS for any CF card housekeeping.

Each day file will usually have 24 ASCII lines

Each ASCII line represents 1 hour of comma delimited data:

Timestamp, X_Tilt, Y_Tilt, T_Tilt, 60Pc<cr><lf>

Timestamp=10char=10bytes	UNIX integer seconds since 1/1/1970 (Timestamp/86400 + 25569 for Excel format)
X_Tilt=5bytes	+xx.x Tilt sensor- Geomechanics (tilt convention follows manual)
Y_Tilt=5bytes	+xx.x +X down = positive degrees, +Y down = positive degrees
T_Tilt=5bytes	+xx.x temperature from tilt sensor inside TG09 p-case
Pc=8-10bytes	pppp.ppppp temperature corrected absolute pressure in psia

.ppppp will always have 5 decimal places. The pppp. just scales with the actual pressure. 14 at the surface, 1000 at the max depth for the 1000 psia pressure transducer although it is limited to 9999 at the max pressure for the 10,000 psia at 6790m.

Timing:

1. Top of each hour: Timestamp, TiltX, TiltY, TiltT,
2. 64 seconds later: Pc
3. 58.5 seconds 59 times : Pc
4. Cycle repeats top of next hour

With the comma delimiters, it is easily read in Excel or MatLab. HyperTerm as configured on the Gravity Group PC_H laptop will not add any extra <cr> or <lf> characters but that is something to watch.

Upload speed:

LinkQuest claims 6600 bps throughput with the UWM2000 modem.
The best to date observed is 4000 bps (off Scripps pier testing May 2009)
Under adverse conditions, it will drop to 1200 bps or slower.

631 bytes/hour x 24 hours = 15,144 bytes/day at 999.99999 psi max pressure for the 31K 1000 psia transducer
1 day @ 1200 bps = 126 seconds or a couple minutes. More or less. 3 days: 6 minutes 20 seconds
1 day @ 4000 bps = 38 seconds. 3 days = 114 seconds

*Until we can establish how well things work or don't work onsite, best to only upload 2-3 days at a time.
If the link hangs, always send a mdm_sync command before leaving the site.*

***** Various Timeouts *****

*** Once the TG09 is awake, there is a 14 minute watchdog timeout counting down regardless of any communication with the LinkQuest modem. Once connected to the LinkQuest modem, send the TG09 ACT1 command to the TG09 CF2 which will reset this watchdog. As long as you are communicating directly with the TG09 CF2, this watchdog keeps getting reset but NOT if you are just communicating with the LinkQuest modem.

*** On the LinkQuest side, there is a 5 minute timeout before it drops into a low power mode. In the LinkQuest low power mode, it wakes briefly every 20 seconds at which time the surface/ROV modem can link to it. This 20 seconds can be changed from 0 (always on, surface/ROV modem) to 120 seconds in increments of 5 seconds.

***** Other 2 CF2 watchdog timeouts: *****

(which should never happen unless...)

7 minutes if something bad happens

Time = 00:00:00 GMT if something really bad happens.

Statoil Tide Gage 2009 (TG09)

Startup Info

1. Install the 2 alkaline deployment battery packs but don't connect yet
(the 2007 lithium battery pack will still fit & work but will require a different connector)
2. Verify small RTC alkaline battery pack is fresh (replace yearly)
3. Service o-rings, if needed
4. Replace desiccant if needed
5. Mount TG09 & LinkQuest modem p-case on deployment stand
6. Connect cables (light silicon spray, no grease)
7. Connect TG09 comm cable to laptop
8. Connect alkaline battery packs
9. Verify startup diagnostic sequence from comm. Port (date, time, tilt, Pc, Pc, Pc, ...)
10. Close TG09 p-case
11. Verify LinkQuest comms with direct LinkQuest Bypass cable (see above)
12. Disconnect Bypass & connect TG09 LinkQuest cable.
13. Disconnect TG09 comm cable
14. Install comm. Dummy plug w/ locking sleeve (silicon spray)
15. Ready to deploy

Paros 1000 psia Model 3100 pressure transducer with intelligence card

Setup Parameters (April 2009, Don't modify!!)

1. PI = 58500 integration time in milliseconds
2. OI = 0 Simultaneous integration of temperature and pressure
3. PS = 1 temperature measurement interval (each pressure reading uses new temp reading)
4. FM = 1 :The Paros is set in 'Fetch' mode where it is continuously calculating temperature compensated pressure.
The unit responds to the P3 command immediately with the most recent reading.
5. Calibration coefficients are set for Serial #103559
6. Units in psia

There is a separate serial/power cable. Refer to the Paros User's Manual to check or change.

Another Paros will work if with the same setup parameters above.

In addition, there is a timebase correction specific to each intelligence card and serial number specific to each Paros transducer.

Max pressure format is 9999.99999 psia

Paros Sampling

We are using the new Paros firmware where the pressure and temperature measurements are simultaneous. This means every pressure sample is always temperature corrected at the same time.

TG09 program code is completely dependent on the Paros being initialized correctly. See the Paros User's Manual.

Set PI=58500 milliseconds, OI=0, PS=1, UN=1 psia, FM=1
Also verify Paros serial # & calibration coefficients all agree

April 2009: We are currently using the settings for the 1000 psia Paros Serial # 103559 which is installed.

This uses the Paros P3 cmd = fetch measurement in psia
Paros has already been initialized w/ separate cable.

Paros intelligence card begins calculating at program start.

P3 command is sent after menu timeout (5 seconds) + sleep period (59 seconds) = 64 seconds
and 59 more times at 59 second intervals for a total of
60 readings and duration of ~3545 seconds for each hour.

After this period, the program shuts down for approximately
55 seconds until the top of the next hour.

This allows a very comfortable margin for each hour.

Changing the top of hour timeout to 2 seconds & PI to 59 or 59.5 seconds will give a 58 second or 28 second margin.

Statoil Tide Gage 2009 (TG09)

*** ***CF2 board Power Jumper******

JP1 (3 pin header, lower right CF2 board)

2-3 (upper 2 pins) Deployment mode, power controlled by RTC & CF2

1-2 (lower 2 pins) Test/Program mode, CF2 always powered

Deployment mode JP1: 2-3 (upper 2 pins)

CF2 & Paros shut down a second before top of each hour

On the hour, the DS1306 RTC powers up the CF2

The Paros is powered continuously

Test/Program mode JP1: 1-2 (lower 2 pins)

CF2 will run TG09 once & revert to PicoDOS

PicoDOS is where new code is loaded also basic flash card ops (dir, format, etc.)

To restart TG09, type app <Enter>

And move the JP1 jumper to deployment mode!!!

Underneath PicoDOS there is another very low level monitor called PBM

You don't want to be here. Type pico <Enter> to return to PicoDOS

If you are in a hurry to breakout of TG09 to PicoDOS, power down, jumper CF2 pin 39 to common & power up. This gets you into the PBM. Type pico <Enter> to return to PicoDOS.

See CF2GSG.pdf page 29-30 to figure out where the CF2 pin 39 is located.

You should read the entire PDF before messing around with the CF2 and its firmware.

Setting the RTC time. The battery backed DS1306 RTC should not need resetting unless the solder wire battery connection is cut or if some adjustment in time is required. To do this, exit to PicoDOS, set the CF time using PicoDOS date or time cmd. From the PicoDOS prompt, run RTC which will set the DS1306 RTC.

Statoil Tide Gage 2009 (TG09) **CF2 Programming Info**

Persistor CF2 Documentation:

C:\Program Files\Persistor\MotoCross Support\CFX\Docs\pdf

Warning: There is great danger in changing firmware. There is much subtle timing and code interactions so changing anything may cause problems that are not immediately apparent.

See above note on the CF2 board power JP1 power jumper.

1. TG09 Project Code:

Kirk2009\Tidegage2009\CF2_Firmware_wjd051109 ***

Do not change this code!!!

If making changes, copy the entire directory and rename it.

*** If changes are made, the date will change and maybe the initials.

Kirk: ... \CF2_Firmware_mrkmmddy

Davis: ... \CF2_Firmware_wjdmddy

Files:

TideGage.mcp Doubleclick *.mcp to start up Code Warrior

Tidemain.c All the TG09 code is here

DS1306.c RTC code needed but don't touch

DS1306.h RTC code needed but don't touch

Motocross.exe communications program between CF2 & laptop

2. Metroworks Code Warrior

Coding, compiling, linking, etc.

3. Persistor Motocross

Terminal program which communicates with the CF2

Download new programs to CF2

*.RUN runs in memory & can be saved to the compact flash card

*.APP gets burned to the CF2 flash (this is the one to use)

Read the CF2 documentation please.

General Development Info

- CF2 powered at the top of each hour, shuts down a few seconds prior the next hour.
- Paros is always powered (takes a few seconds to warm up if switched)
- LinkQuest modem always powered. You can still connect if the CF2 is shut down, just wait for it to wake again.
- Once the CF2 is activated, it will shut down with the EXITI cmd or 14 minutes of no activity.

- There are 2 internal alkaline battery packs: LinkQuest modem (24V) & TG09 Datalogger (12V)
(alkaline 'D' cells discharge fairly linearly from 1.56V to 0.8V per cell)
 - Modem 15 cell pack: 23.4V to 12.0V
 - TG09 Datalogger 8 cell pack (2 in parallel): 12.5V to 6.4V

Tide Gage Components

1. TG09 p-case

main electronics:

MPL CF2 controller

RTC board attached to back of the MPL CF2 board

RTC 4.5V (3 AA pack) - critical, solder wires to CF2

Power for over a year BUT CHANGE THIS YEARLY

COM1 (J3) Serial to LinkQuest modem

COM2 (J4) Serial / switched 9V power to tilt sensor

COM3 (J5) Serial / +9V power to Paros board

Statoil Tide Gage 2009 (TG09)

CF2 COM (J2) Serial to p-case Comm Port connector (test/debug out only)

Paroscientific 1000 psia Model 31K pressure transducer w/ intelligence card
+9 V provides power
Tx, Rx RS232 communications

Tilt sensor- Geomechanics

tilt convention follows Geomechanics manual:

+X down = positive degrees, +Y down = positive degrees

p-case bulkhead connectors:

8 pin data/power cable to LinkQuest modem p-case

5 pin comm cable for testing, dummy for deployment

2. Battery Pack Wiring Harness

2 battery packs connect here

+12V to MPL CF2 J7

+24V sense resistor output to MPL CF2 J1

+24V to LinkQuest modem (SubConn MCBH8F, Pin 3: +V & Pin 7 Power Common)

4. 2 internal alkaline battery packs: LinkQuest modem (24V) & TG09 Datalogger (12V)

(alkaline 'D' cells discharge fairly linearly from 1.56V to 0.8V per cell.

Modem 15 cell pack: 23.4V to 12.0V

TG09 Datalogger 8 cell pack (2 in parallel): 12.5V to 6.4V

5. LinkQuest modem transducer (external p-case)

6. Cables

TG09 to LinkQuest modem

TG09 to laptop (surface test & diagnostics)

Dummy plug for Comm port bulkhead

7. Surface/ROV LinkQuest modem

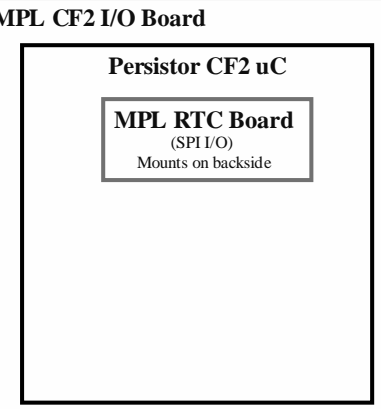
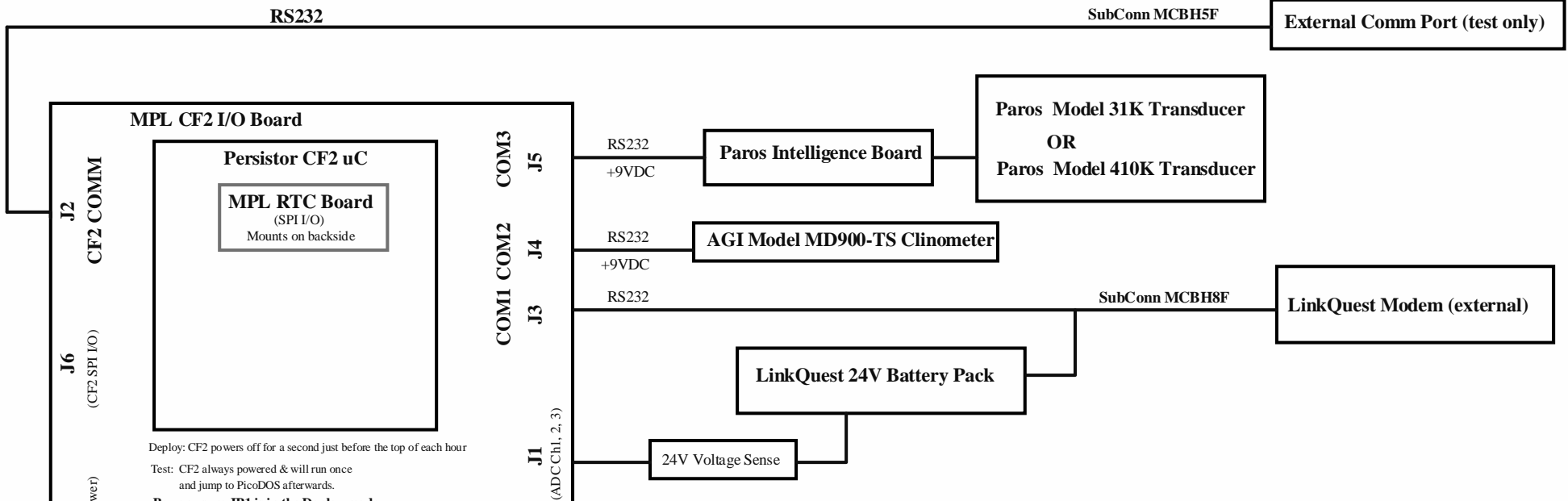

Deploy: CF2 powers off for a second just before the top of each hour
 Test: CF2 always powered & will run once and jump to PicoDOS afterwards.
Be very sure JP1 is in the Deploy mode
Run at least 2 hours to verify this!

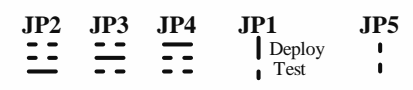

Jumpers (2 pins)
 JP1 2-3 Deploy
 JP1 1-2 Test
 JP2 OFF (no modem power)
 JP3 S-WARE (Tilt switched 9V)
 JP4 ON (Paros always powered)
 JP5 Open (no jumper)
 (JP5 jumped to 3.3V is another way to test mode)

Pin #	J1 ADC Inputs	J2 CF2 Comm (test)	LinkQuest Modem J3 COM1	Tilt J4 COM2	Paros J5 COM3	Not used TG09 J6 SPI I/O	J7 +12V Battery Pack
1	common	common	common	common	common	SCK	common
2	Ch1 +24V sense	Tx (out)	Rx (in)	Rx (in)	Rx (in)	MOSI	VBAT (RTC battery sense)
3	Ch2 - nc	Rx (in)	Tx (out)	Tx (out)	Tx (out)	MISO	+12 VDC
4	Ch3 - nc	+12V	nc	+9V (switched)	+9V (switched)	PCS1	1x3 c-grid
5	1x4 c-grid	nc	1x4 c-grid	1x4 c-grid	1x4 c-grid	PCS3	
6		1x5 c-grid				TPU4	
7						TPU6	
8						JP5-1	
						1x8 c-grid	

RTC Backup Battery
 (Soldered Connection)

CF2/Paros 12V Battery Pack

On actual Persistor CF2 Board
 Jump C50 (CTS) to C41 (IRQ2)
 (wire wrap works well)
 See the CF2 Getting Started Guide p. 26
 C49 LinkQuest Tx (RS232 level)
 C50 LinkQuest Tx (logic level)
 C41 IRQ2 breaks into data logging

DB9F to PC
 2 Rx (data in from a Tx)
 3 Tx (data out to Rx)
 5 common

Title TG09 Function Blocks			
Project StatOil 2009 Tide Gauge	Printed 5/19/2009	5:06:57 PM	
Number	Revision		
Drawn by Mike Kirk	5/18/2009 Tel: 858-534-6729		
File: F:\Mark.Zamberg\2008\TideGage\2009\Schematics\ROVTIDE2009B\Bock_SchDoc			
Size	B		
Sheet 1 of 1	Hydraulics Laboratory Scripps Institution of Oceanography University of California, San Diego 9500 Gilman Drive La Jolla, California 92093-0222		



TIDEGAGE 2009 Battery Connectors

Molex Minifit
2 Pos. Male
(SIDE VIEW)

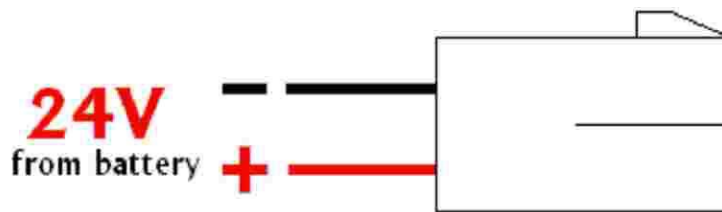

Molex Minifit
4 Pos. Male
(FACE VIEW)

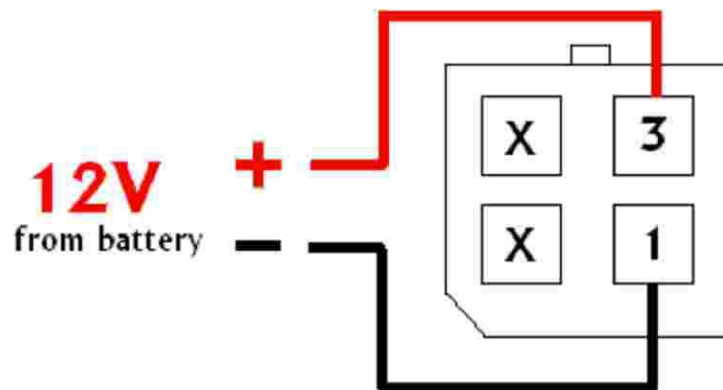

STATOIL 2009 CF2/Paros BATTERY PACK

Notes:

1. Battery Spec: Duracell MN1300 'D' cells
2. Lead Wires: 18" long, min., #18AWG stranded wire with PVC insulation; exit from top of pack
3. Assembly: make 4 cell sticks, series 2 for +12V (16 cells arranged 4 x 4 as shown)
4. Use clear shrink wrap & tubing
5. Diode connections to be visible

ALL CELLS: DURACELL MN1300 ("D") Cells

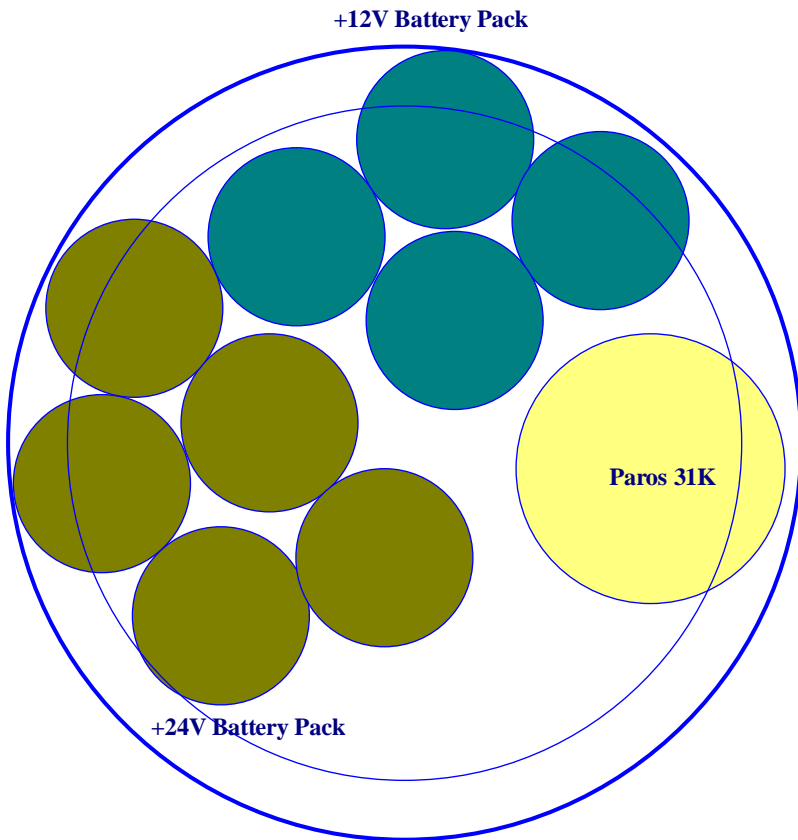
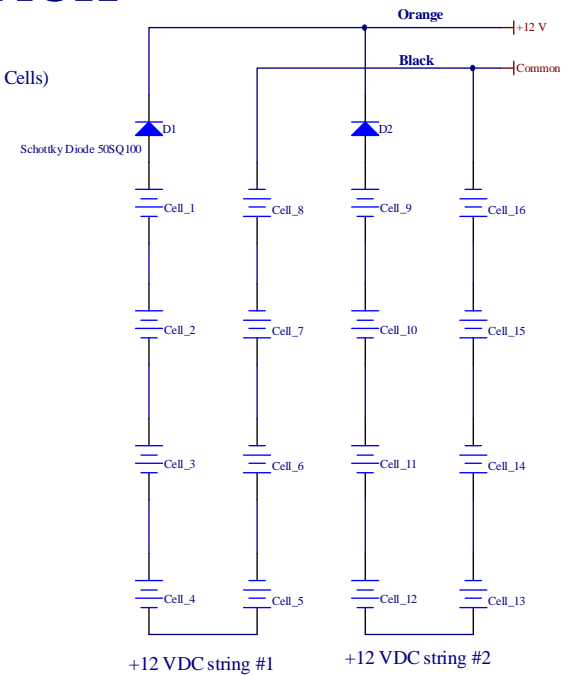
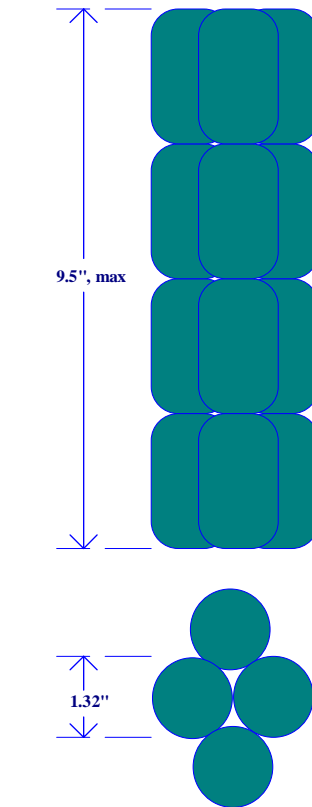

Title TG CF2/Paros Battery Pack		
Project StaOil 2009 Tide Gauge Printed 4/10/2009 5:12:50 PM		
Number IGPP041009 Revision		
Drawn by Mike Kirk 4/10/09 Tel: 858-534-6729 File: F:\Mark Zumberg\c2008\ROVDOG\Schematics\ROVTIDE2007\BatPak\ROVTIDE2009\Paros_BatPak.SCHDOC		
Size B	Hydraulics Laboratory Scripps Institution of Oceanography University of California, San Diego 9500 Gilman Drive La Jolla, California 92093-0222	
Sheet 1 of 1		

STATOIL 2009 Modem BATTERY PACK

Notes:

1. Battery Spec: Duracell MN1300 'D' cells
2. Lead Wires: 18" long, min., #18AWG stranded wire with PVC insulation; exit from top of pack
3. Assembly: make 4 cell sticks, series 2 for +12V (16 cells arranged 4 x 4 as shown)
4. Use clear shrink wrap & tubing
5. Diode connections to be visible

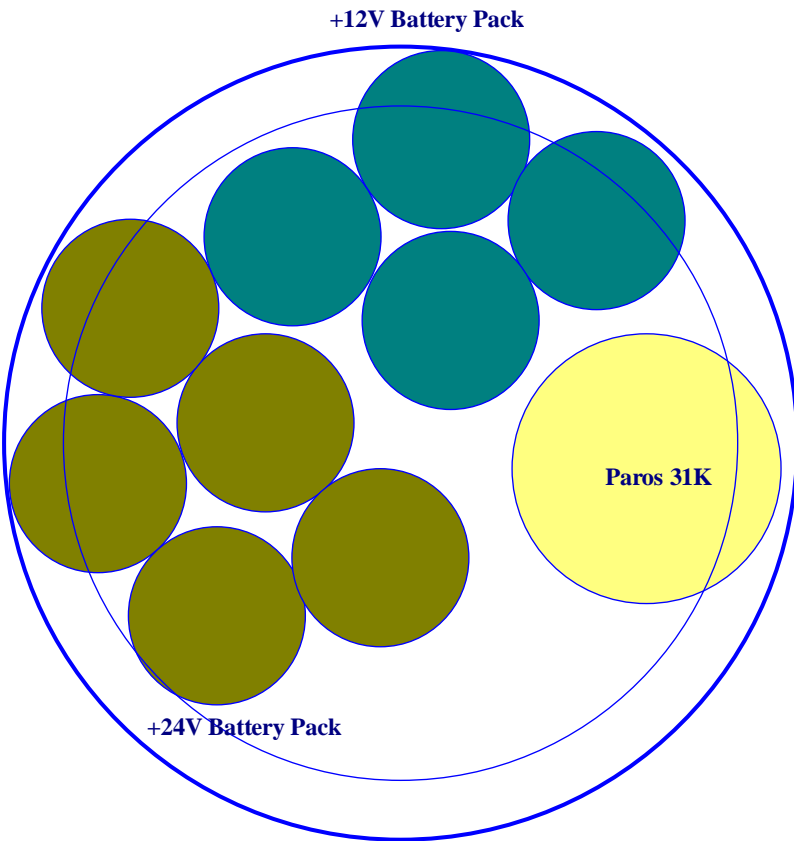

ALL CELLS: DURACELL MN1300 ("D" Cells)

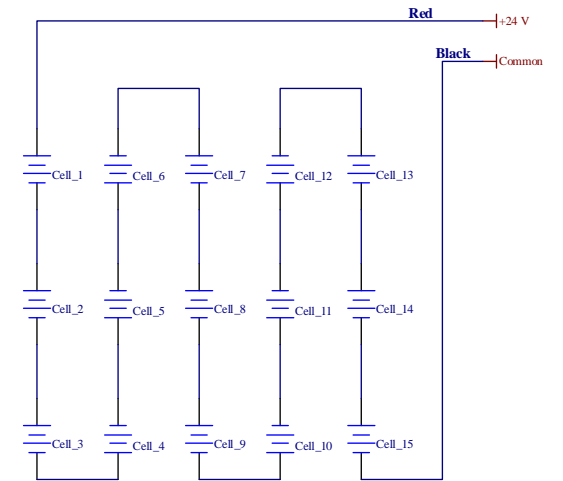
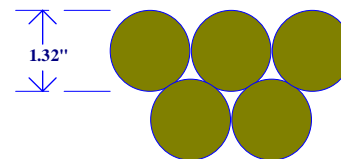
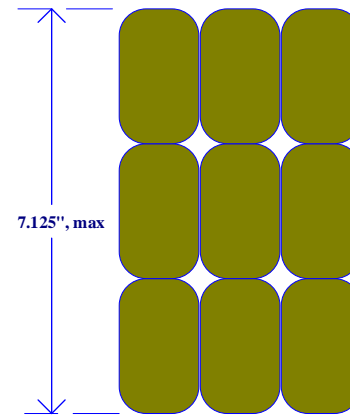

Title TG2009 Modem Battery Pack		
Project StatOil Tide Gauge 2009 Printed 4/10/2009 5:11:42 PM		
Number IGPP040909 Revision		
Drawn by Mike Kirk 4/10/2009 Tel: 858-534-6729 File: F:\Mark Zamberg\2008\ROVDOG_Schematics\ROVTIDE2007\BatPak\ROVTIDE2009Modem_BatPakSCHDOC		
Size B	Hydraulics Laboratory Scripps Institution of Oceanography University of California, San Diego 9500 Gilman Drive La Jolla, California 92093-0222	
Sheet 1 of 1		

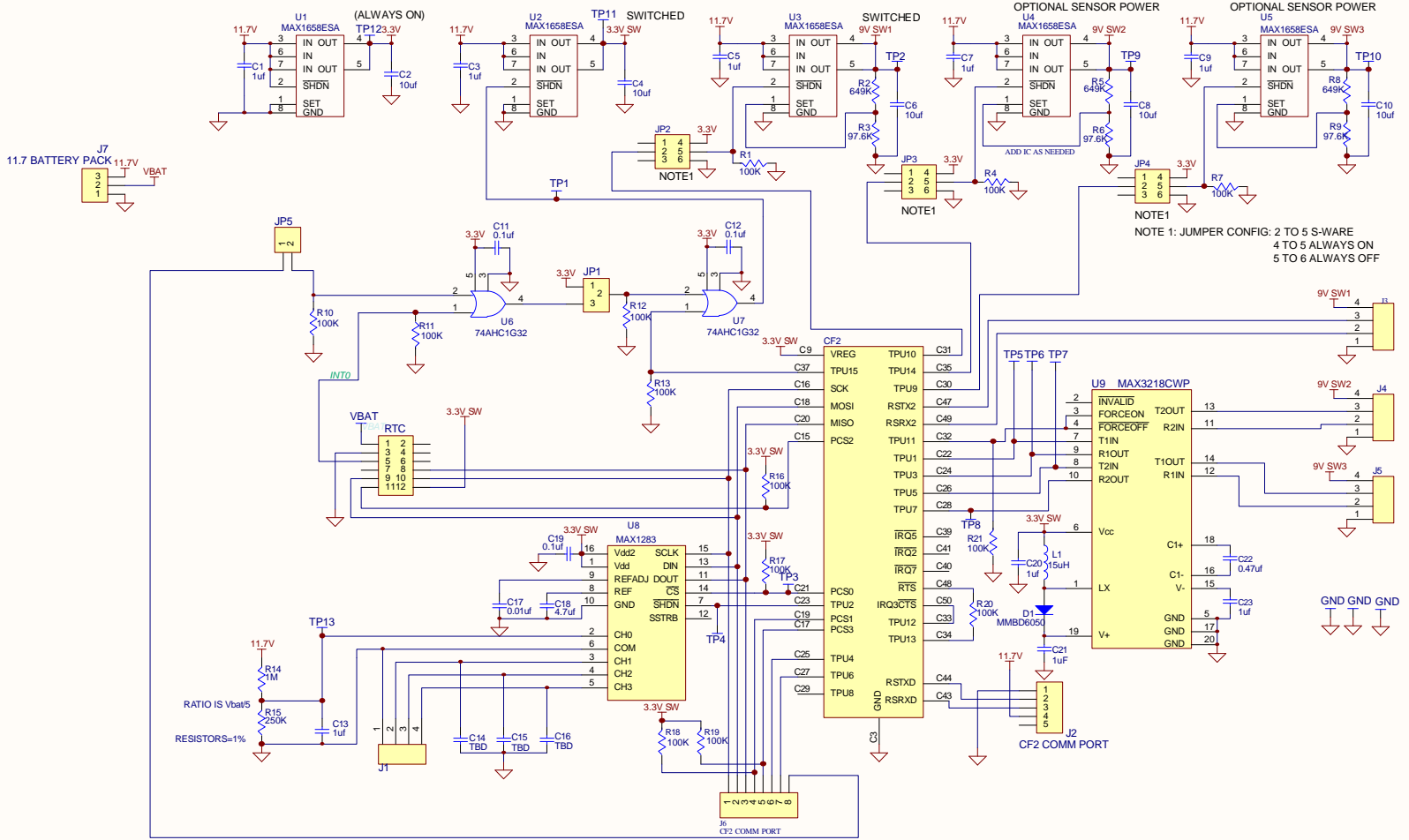

Title		
GENERIC CF2 BOARD w RTC Connector		
Size	Number	Revision
C	GENCF2.SCHDOC	01/28/2005
Date:	4/14/2005	Sheet of
File:	C:\Documents and Settings\CL... \GENCF2.SCHDOC	2

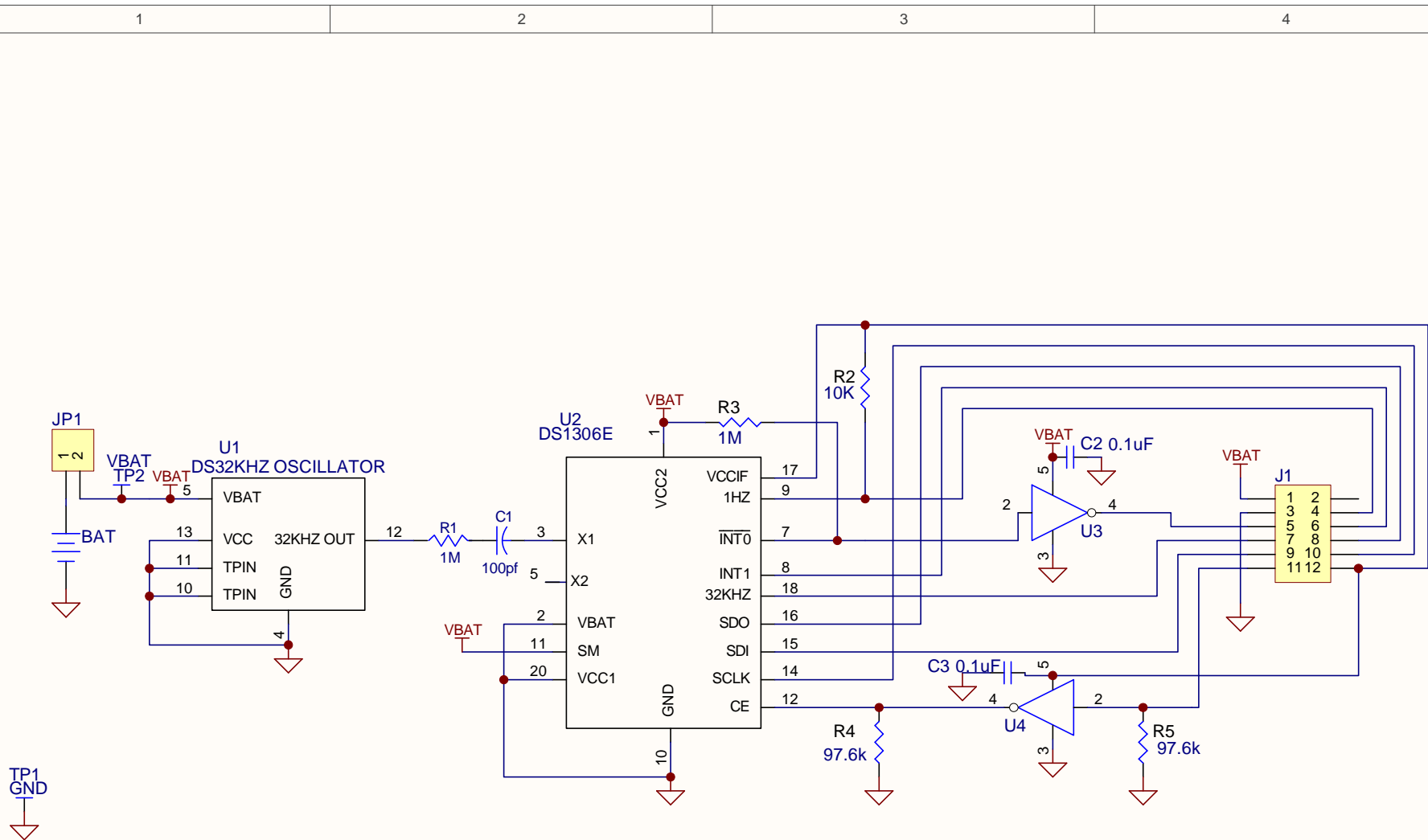

- 1) TIE SDO AND SDI TOGETHER FOR 3 WIRE OPERATION
- 2) LITHIUM BATTERY
- 3) VccIf has to be <= Vcc2
- 4) U3 & U4 PART NUMBER 74AHC1G04DBVR

Title		
REAL TIME CLOCK 2005		
Size	Number	Revision
Letter	REALTIME CLOCK 2005.SCHDOC	01-31-2005
Date:	4/14/2005	Sheet of
File:	C:\Documents and Settings\REALTIME\My Documents\REALTIME\CLOCK 2005.SCHDOC	1

SPECIFICATION CONTROL DRAWING

STANDARD PRODUCT

NOTES:

- POWER REQUIREMENTS:
OPERATES FROM +6 VDC MIN TO +16 VDC MAX.
RECOMMENDED INPUT VOLTAGE IS +6 VDC.
TYPICAL AVERAGE SUPPLY CURRENT: 7 mA IN SLEEP MODE
12 mA QUIESCENT
16 mA MAX
- OPERATING TEMPERATURE RANGE: -54 °C TO +70 °C. (-65 °F TO +158 °F)
- LOGIC LEVELS OF DIGITAL I/O SIGNALS IS 0-3.3 VDC NOMINAL.
- PCB IS CONFORMAL COATED WITH HUMISEAL 1B31/S.
- KIT 1764-001 INCLUDES MOUNTING CLIP (3660-001), INTELLIGENT PCA (4123-001), 28-AWG HOOK-UP WIRES; DIGIQUARTZ CD LIBRARY (6732-201), AND OPERATIONS MANUAL (8819-001).

-CAUTION-
THIS CIRCUIT BOARD ASSEMBLY IS STATIC SENSITIVE AND SHOULD BE PROTECTED FROM STATIC DISCHARGE

28-AWG POWER AND SIGNAL WIRES
9.5 (24.13) MIN LENGTH

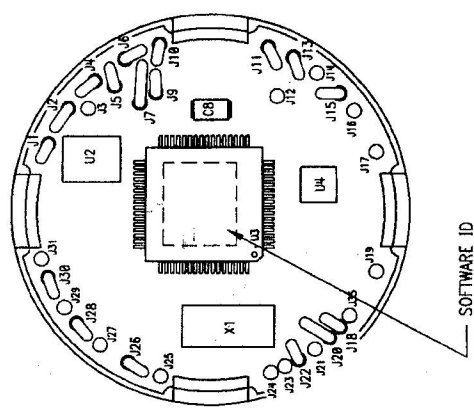

28-AWG POWER AND SIGNAL WIRES
9.5 (24.13) MIN LENGTH

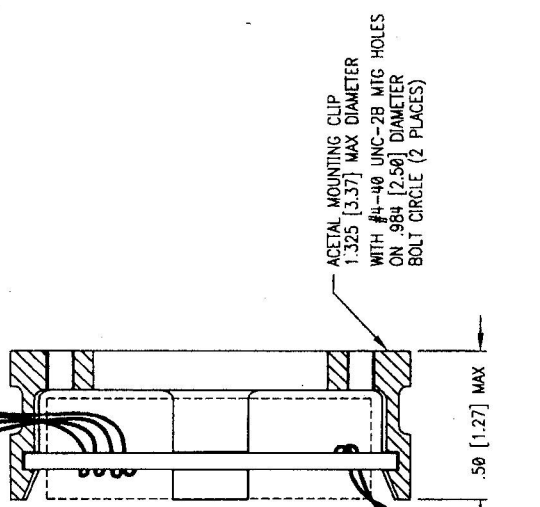

ACETAL MOUNTING CLIP
1.325 (3.37) MAX DIAMETER
WITH #4-40 UNC-2B MTG HOLES
ON .984 (2.50) DIAMETER
BOLT CIRCLE (2 PLACES)

BOARD WIRING:

PIAD	SIGNAL	WIRE COLOR
J5	RS-485 RX+	WHITE/GREEN
J4	RS-485 RX-	WHITE/BLUE
J1	RS-485 TX+	WHITE/RED
J2	RS-485 TX-	WHITE/BLACK
J15	RS-232 TX	YELLOW
J13	RS-232 RX	ORANGE
J9	TARE IN	GREEN
J11	OVERPRESSURE	VIOLET
J10	TARE OUT	BROWN
J7	GND	BLACK
J18	PWR TO XDCR	RED
J20	POWER IN	RED
J22	GND	BLACK
J28	PRESSURE	BLUE
J26	GND	BLACK
J30	TEMPERATURE	WHITE

KIT P.N. 1764-001

NAME: R.M. Collado DATE: 01/23/07 CHK: [Signature] ENG: [Signature]		CURRENT APPROVALS NAME: [Signature] DATE: 12/10/07 NAME: [Signature] DATE: 12/10/07 NAME: [Signature] DATE: 1-24-07		DESCRIPTION KIT, INTELLIGENT RS-232/RS-485 BRD	
4500 148th Avenue NE Redmond, WA 98052 Tel: 425.883.2700 Fax: 425.867.5497 Website: www.paroscientific.com		Paroscientific, Inc.		SIZE: A CASE: 54535 DOCUMENT NUMBER: 7536-003 SCALE: NONE	
UNLESS OTHERWISE SPECIFIED ALL DIMENSIONS ARE IN INCHES DIMENSIONS IN BRACKETS ARE IN CENTIMETERS		ACAD FILENAME: 7536-003_NC		SHEET 1 OF 1	

5/1/2009

TG09 U/W Tide Gauge Connectors

Lid #	Name	Bulkhead #	Dummy #	Cable1#	Dummy1 #	Cable2 #	Dummy2 #
1	Comm	MCBH5F	MCDC5M	MCIL5M	MCDC5F	DB9, Laptop	
2	LinkQuest (Paros in internal for TG09)	MCBH8F	MCDC8M	MCIL8M	MCDC8F	MCIL8F	MCDC8M

These are SubConn connectors.

Connector & Cable Source for all u/w types especially hybrids:

Brock Rosenthal
OCEAN INNOVATIONS

La Jolla, CA 92037
Tel: 858-454-4044
Fax: 858-454-5775
email: brock@o-ventions.com

Notes:

Existing Benthos cables also work for the new LinkQuest modems.

TIDEGAGE 2009

ROV LINKQUEST BYPASS CABLE

from Linkquest Cable

to ROVDOG Cable Tester

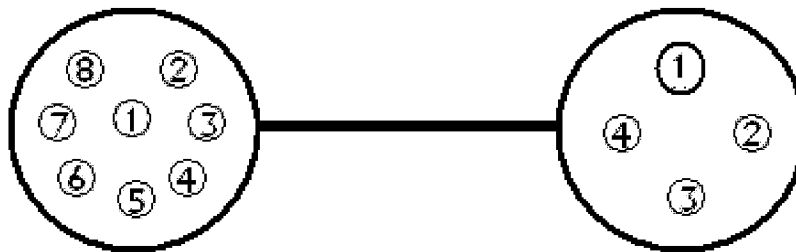

SubConn 8 pin Male
(Face View)

Sea-Con 4 pin Female
(Face View)

- | | | |
|-----------------------|-------|-------------------|
| 1- Downlink (Black) | ----- | 2- Uplink (Black) |
| 2- Uplink (White) | ----- | 4- Downlink (Red) |
| 3- Power + (Red) | ----- | 3- +24V (Green) |
| 4- 232 Com. (Green) | ----- | 1- Common (White) |
| 7- Power Com(wht/blk) | ----- | |